

CE/EMC TEST REPORT

Applicant: TTAF ELEKTRONIK SAN VE TIC A.S.
Address: Kavakli Mah. Istanbul Cad. No:21 34520 Beylikduzu /Istanbul/Turkey
Manufacturer: TTAF ELEKTRONIK SAN VE TIC A.S.
Address: Kavakli Mah. Istanbul Cad. No:21 34520 Beylikduzu /Istanbul/Turkey
EUT: AROMA DIFFUSER
Trademark: 
Model Number: T-BHR-01
T-BHR-28, T-BHR-560, T-BHR-550, T-BHR-1702, T-BHR-1804, T-BHR-11,
T-BHR-43
Test Date: Jul. 12, 2020 - Jul. 16, 2020
Date of Report: Jul. 16, 2020
Report No.: SiCT200509178E
Test Result: The equipment under test was found to be compliance with the requirements of the standards applied.

Test Procedure Used:

EMI : EN 55014-1:2017
EN 61000-3-2:2019, EN 61000-3-3:2013+A1:2019
EMS : EN 55014-2:2015
EN 61000-4-2:2009, EN 61000-4-3:2006+A1:2008+A2:2010,
EN 61000-4-4:2012, EN 61000-4-5:2014+A1:2017,
EN 61000-4-6:2014/AC:2015, EN 61000-4-8:2010,
EN 61000-4-11:2004+A1:2017

Compiled by:



Smile Xu

Reviewed by:



Snow Wu

Approved by:



Jasse Liu, Manager



This test report is based on a single evaluation of one sample of above mentioned products. It is not permitted to be duplicated in extracts without written approval of Shenzhen SiCT.Labs Technology Co., Ltd.

TABLE OF CONTENT

	Page
Test Report Declaration	4
1. GENERAL INFORMATION.....	4
1.1. Description of Device (EUT)	4
1.2. Tested System Details.....	4
1.3. Test Uncertainty.....	4
2. TEST INSTRUMENT USED.....	5
3. CONDUCTED EMISSION AT THE MAINS TERMINALS TEST.....	8
3.1. Block Diagram Of Test Setup	8
3.2. Test Standard	8
3.3. Power Line Conducted Emission Limit	8
3.4. EUT Configuration on Test	8
3.5. Operating Condition of EUT	8
3.6. Test Procedure	9
3.7. Test Result.....	9
4. RADIATION EMISSION TEST.....	12
4.1. Block Diagram of Test Setup.....	12
4.2. Test Standard	12
4.3. Radiation Limit.....	12
4.4. EUT Configuration on Test	12
4.5. Operating Condition of EUT	12
4.6. Test Procedure	12
4.7. Test Result.....	12
5. HARMONIC CURRENT EMISSION TEST	14
5.1. Block Diagram of Test Setup.....	14
5.2. Test Standard	14
5.3. Operating Condition of EUT	14
5.4. Test Procedure	14
5.5. Test Results.....	14
6. VOLTAGE FLUCTUATIONS & FLICKER TEST	15
6.1. Block Diagram of Test Setup.....	15
6.2. Test Standard	15
6.3. Operating Condition of EUT	15
6.4. Test Procedure	15
6.5. Test Results.....	15
7. ELECTROSTATIC DISCHARGE IMMUNITY TEST	17
7.1. Block Diagram of Test Setup.....	17
7.2. Test Standard	17
7.3. Severity Levels and Performance Criterion	17
7.4. EUT Configuration.....	18
7.5. Operating Condition of EUT	18
7.6. Test Procedure	18
7.7. Test Results.....	19
8. RF FIELD STRENGTH SUSCEPTIBILITY TEST	20
8.1. Block Diagram of Test Setup.....	20
8.2. Test Standard	20
8.3. Severity Levels and Performance Criterion	20
8.4. EUT Configuration on Test	21
8.5. Operating Condition of EUT	21
8.6. Test Procedure	21
8.7. Test Results.....	22

9.	ELECTRICAL FAST TRANSIENT/BURST IMMUNITY TEST	23
9.1.	Block Diagram of EUT Test Setup.....	23
9.2.	Test Standard	23
9.3.	Severity Levels and Performance Criterion	23
9.4.	EUT Configuration on Test	24
9.5.	Operating Condition of EUT	24
9.6.	Test Procedure	24
9.7.	Test Results.....	25
10.	SURGE TEST	26
10.1.	Block Diagram of EUT Test Setup.....	26
10.2.	Test Standard	26
10.3.	Severity Levels and Performance Criterion	26
10.4.	EUT Configuration on Test.....	27
10.5.	Operating Condition of EUT	27
10.6.	Test Procedure	27
10.7.	Test Result.....	28
11.	INJECTED CURRENTS SUSCEPTIBILITY TEST	29
11.1.	Block Diagram of EUT Test Setup.....	29
11.2.	Test Standard	29
11.3.	Severity Levels and Performance Criterion	29
11.4.	EUT Configuration on Test.....	30
11.5.	Operating Condition of EUT	30
11.6.	Test Procedure	30
11.7.	Test Result.....	30
12.	VOLTAGE DIPS AND INTERRUPTIONS TEST	32
12.1.	Block Diagram of EUT Test Setup.....	32
12.2.	Test Standard	32
12.3.	Severity Levels and Performance Criterion	32
12.4.	EUT Configuration on Test.....	33
12.5.	Operating Condition of EUT	33
12.6.	Test Procedure	33
12.7.	Test Result.....	33
13.	PHOTOS OF TEST SETUP	34
14.	EUT PHOTOGRAPHS.....	35

1. GENERAL INFORMATION

1.1. Description of Device (EUT)

EUT : AROMA DIFFUSER

Trademark : The logo for TTAF consists of three red hexagons of varying sizes arranged in a triangular pattern to the left of the letters 'TTAF' in a bold, red, sans-serif font. A registered trademark symbol (®) is located at the top right of the 'F'.

Model Number : T-BHR-01
: T-BHR-28, T-BHR-560, T-BHR-550, T-BHR-1702,
T-BHR-1804, T-BHR-11, T-BHR-43

Power Supply : AC 220-240V 50/60Hz

1.2. Tested System Details

None.

1.3. Test Uncertainty

Conducted Emission
Uncertainty : $\pm 2.66\text{dB}$

Radiated Emission Uncertainty : $\pm 4.26\text{dB}$

2. TEST INSTRUMENT USED

For Conducted Emission at the mains terminals Test

Conducted Emission Test (A --- site)					
Equipment	Manufacturer	Model#	Serial#	Last Cal.	Next Cal.
843 Shielded Room	ChengYu	843 Room	843	Dec. 27, 2019	Dec. 26, 2020
EMI Receiver	R&S	ESCI	101421	Dec. 27, 2019	Dec. 26, 2020
LISN	SCHWARZBECK	NSLK8127	812779	Dec. 27, 2019	Dec. 26, 2020
Pulse Limiter	R&S	ESH3-Z2	100681	Dec. 27, 2019	Dec. 26, 2020
843 Cable 1#	FUJIKURA	843C1#	001	Dec. 27, 2019	Dec. 26, 2020

For Disturbance Power Test

Conducted Emission Test (A --- site)					
Equipment	Manufacturer	Model#	Serial#	Last Cal.	Next Cal.
EMI Receiver	R&S	ESCI	101421	Dec. 27, 2019	Dec. 26, 2020
Power Clamp	LUTHI	MDS21	4293	Dec. 27, 2019	Dec. 26, 2020
Attenuator	R&S	ESH3-Z2	BCTC021E	Dec. 27, 2019	Dec. 26, 2020
843 Cable 2#	FUJIKURA	843C1#	002	Dec. 27, 2019	Dec. 26, 2020

For Radiated Emission Test

Radiation Emission Test (966 chamber)					
Equipment	Manufacturer	Model#	Serial#	Last Cal.	Next Cal.
966 chamber	ChengYu	966 Room	966	Dec. 27, 2019	Dec. 26, 2020
Spectrum Analyzer	Agilent	E4407B	MY45109572	Dec. 27, 2019	Dec. 26, 2020
Amplifier	Schwarzbeck	BBV9743	9743-119	Dec. 27, 2019	Dec. 26, 2020
Amplifier	Schwarzbeck	BBV9718	9718-270	Dec. 27, 2019	Dec. 26, 2020
Log-periodic Antenna	Schwarzbeck	VULB9160	VULB9160-3369	Dec. 27, 2019	Dec. 26, 2020
EMI Receiver	R&S	ESCI	101421	Dec. 27, 2019	Dec. 26, 2020
Horn Antenna	Schwarzbeck	BBHA9120D	9120D-1275	Dec. 27, 2019	Dec. 26, 2020
966 Cable 1#	CHENGYU	966	004	Dec. 27, 2019	Dec. 26, 2020
966 Cable 2#	CHENGYU	966	003	Dec. 27, 2019	Dec. 26, 2020

For Harmonic & Flicker Test

For Harmonic / Flicker Test (A --- site)					
Equipment	Manufacturer	Model#	Serial#	Last Cal.	Next Cal.
Harmonic / Flicker Analyzer	KIKUSUI	KHA1000	VA002445	Dec. 27, 2019	Dec. 26, 2020
AC Power Supply	KIKUSUI	PCR4000M	UK001879	Dec. 27, 2019	Dec. 26, 2020
Line Impedance network	KIKUSUI	LIN1020JF	UL001611	Dec. 27, 2019	Dec. 26, 2020

For Electrostatic Discharge Immunity Test

For Electrostatic Discharge Immunity Test (A --- site)					
Equipment	Manufacturer	Model#	Serial#	Last Cal.	Next Cal.
ESD Tester	KIKISUI	KES4201A	UH002321	Dec. 27, 2019	Dec. 26, 2020

For RF Field Strength Susceptibility Test(SMQ)

For RF Field Strength Susceptibility Test (SMQ --- site)					
Equipment	Manufacturer	Model#	Serial#	Last Cal.	Next Cal.
Signal Generator	HP	8648A	3625U00573	Dec. 27, 2019	Dec. 26, 2020
Amplifier	A&R	500A100	17034	Dec. 27, 2019	Dec. 26, 2020
Amplifier	A&R	100W/1000M1	17028	Dec. 27, 2019	Dec. 26, 2020
Audio Analyzer (20Hz~1GHz)	Panasonic	2023B	202301/428	Dec. 27, 2019	Dec. 26, 2020
Isotropic Field Probe	A&R	FP2000	16755	Dec. 27, 2019	Dec. 26, 2020
Antenna	EMCO	3108	9507-2534	Dec. 27, 2019	Dec. 26, 2020
Log-periodic Antenna	A&R	AT1080	16812	Dec. 27, 2019	Dec. 26, 2020

For Electrical Fast Transient /Burst Immunity Test

For Electrical Fast Transient/Burst Immunity Test (A --- site)					
Equipment	Manufacturer	Model#	Serial#	Last Cal.	Next Cal.
Burst Tester	Prima	EFT61004AG	PR14054467	Dec. 27, 2019	Dec. 26, 2020
Coupling Clamp	Prima	EFT61004AG	BCTC009E	Dec. 27, 2019	Dec. 26, 2020

For Surge Test

For Surge Test (A --- site)					
Equipment	Manufacturer	Model#	Serial#	Last Cal.	Next Cal.
Burst Tester	Prima	EFT61004AG	PR14054467	Dec. 27, 2019	Dec. 26, 2020

For Injected Currents Susceptibility Test

For Injected Currents Susceptibility Test (A --- site)					
Equipment	Manufacturer	Model#	Serial#	Last Cal.	Next Cal.
C/S Test System	SCHLODER	CDG600	126B1281	Dec. 27, 2019	Dec. 26, 2020
CDN	SCHLODER	CDN-M2+3	A2210320/20 15	Dec. 27, 2019	Dec. 26, 2020
Injection Clamp	SCHLOBER	EMCL-20	132A1214/20 15	Dec. 27, 2019	Dec. 26, 2020

For Voltage Dips Interruptions Test

For Voltage Dips Interruptions Test (A --- site)					
Equipment	Manufacturer	Model#	Serial#	Last Cal.	Next Cal.
Dips Tester	Prima	DRP61011AG	PR14086284	Dec. 27, 2019	Dec. 26, 2020

3. CONDUCTED EMISSION AT THE MAINS TERMINALS TEST

3.1. Block Diagram Of Test Setup

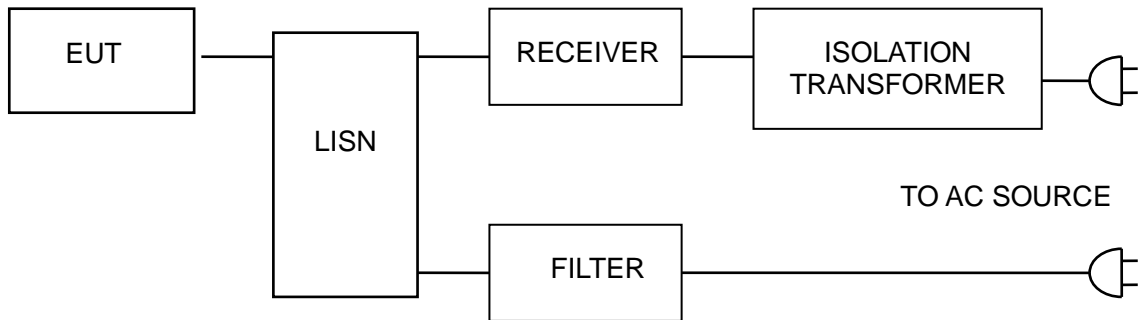

3.2. Test Standard

EN 55014-1

3.3. Power Line Conducted Emission Limit

Frequency MHz	Limits dB(μV)	
	Quasi-peak Level	Average Level
0.15 ~ 0.50	66 ~ 56*	56 ~ 46*
0.50 ~ 5.00	56	46
5.00 ~ 30.00	60	50

Notes: 1. *Decreasing linearly with logarithm of frequency.

2. The lower limit shall apply at the transition frequencies.

3.4. EUT Configuration on Test

The following equipments are installed on conducted emission test to meet EN 55014-1 requirement and operating in a manner which tends to maximize its emission characteristics in a normal application.

3.5. Operating Condition of EUT

3.5.1 Setup the EUT and simulators as shown in Section 3.1.

3.5.2 Turn on the power of all equipments.

3.5.3 Let the EUT work in test modes and test it.

3.6. Test Procedure

The EUT is put on the ground and connected to the AC mains through a Artificial Mains Network (AMN). This provided a 50ohm coupling impedance for the tested equipments. Both sides of AC line are checked to find out the maximum conducted emission levels according to the **EN 55014-1** regulations during conducted emission test.

The bandwidth of the test receiver (R&S Test Receiver ESCI) is set at 10KHz.

The frequency range from 150 KHz to 30 MHz is investigated.

3.7. Test Result

PASS

Please refer to the following page.

Conducted Emission At The Mains Terminals Test Data

Temperature:	24.5 °C	Relative Humidity:	54%
Pressure:	1009hPa	Phase :	Line
Test Voltage:	AC 230V/50Hz	Test Mode:	On Mode

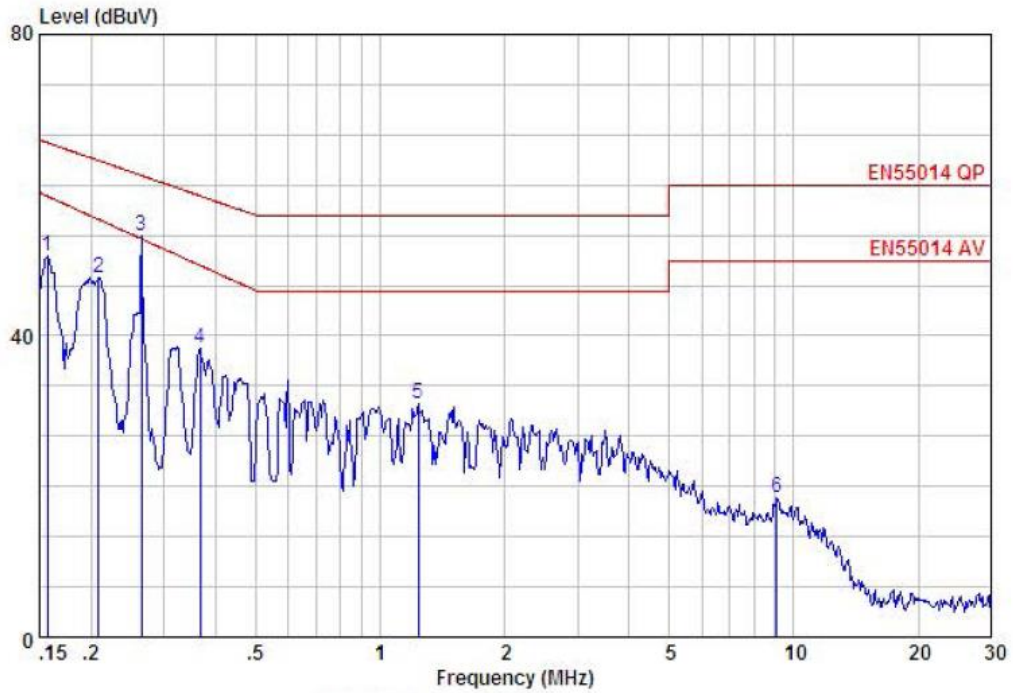

	Freq	Level	Pol/Phase	Read Level	Limit Line	Over Limit	Remark
	MHz	dBuV		dBuV	dBuV	dB	
1	0.16	50.66	LINE	50.66	65.65	-14.99	Peak
2	0.21	47.76	LINE	47.76	63.27	-15.51	Peak
3 max	0.26	53.35	LINE	53.35	61.29	-7.94	Peak
4	0.37	38.36	LINE	38.36	58.56	-20.20	Peak
5	1.24	30.93	LINE	30.93	56.00	-25.07	Peak
6	9.11	18.60	LINE	18.60	60.00	-41.40	Peak

Conducted Emission At The Mains Terminals Test Data			
Temperature:	24.5 °C	Relative Humidity:	54%
Pressure:	1009hPa	Phase :	Neutral
Test Voltage:	AC 230V/50Hz	Test Mode:	On Mode

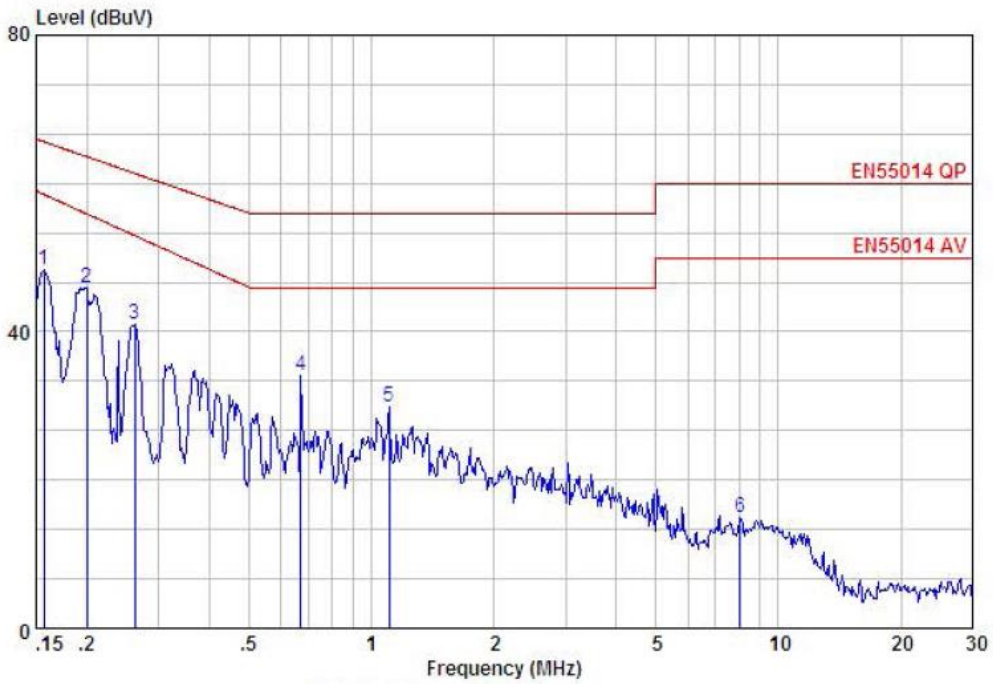

	Freq	Level	Pol/Phase	Read Level	Limit Line	Over Limit	Remark
	MHz	dBuV		dBuV	dBuV	dB	
1 max	0.16	48.39	NEUTRAL	48.39	65.65	-17.26	Peak
2	0.20	45.95	NEUTRAL	45.95	63.62	-17.67	Peak
3	0.26	40.96	NEUTRAL	40.96	61.36	-20.42	Peak
4	0.67	34.07	NEUTRAL	34.07	56.00	-21.93	Peak
5	1.11	29.87	NEUTRAL	29.87	56.00	-26.13	Peak
6	8.06	14.88	NEUTRAL	14.88	60.00	-45.12	Peak

4. RADIATION EMISSION TEST

4.1. Block Diagram of Test Setup

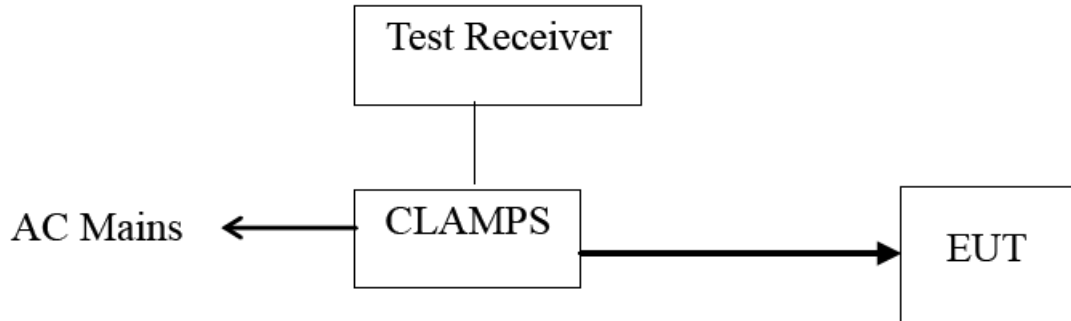

4.2. Test Standard

EN 55014-1

4.3. Radiation Limit

Frequency MHz	Quasi-peak Value dB(pW)	Average Value dB(pW)
30 ~ 300	45 Increasing Linearly with Frequency to 55 (Q.P.)	35 Increasing Linearly with Frequency to 45 (A.V.)

4.4. EUT Configuration on Test

The EN 55014-1 regulations test method must be used to find the maximum emission during radiated emission test.

The configuration of EUT is the same as used in conducted emission test. Please refer to Section 2.2.

4.5. Operating Condition of EUT

Same as conducted emission test, which is listed in Section 2.2 except the test set up replaced as Section 4.1.

4.6. Test Procedure

The EUT is placed on the ground and away from other metallic surface at least 0.4m. It is connected to the power mains through an extension cord of 6m min. The absorber clamp clamps the cord and moves from the far end to the EUT to measure the disturbing energy emitted from the cord.

The bandwidth of the test receiver is set at 120kHz.

All the test results are listed in Section 6.6.

The frequency spectrum from 30 MHz to 300 MHz is investigated.

4.7. Test Result

PASS

Please refer to the following page.

Radiation Emission Test Data			
Temperature:	24.5 °C	Relative Humidity:	54%
Pressure:	1009hPa	Test Line	AC Line
Test Voltage:	AC 230V/50Hz	Test Mode:	On Mode

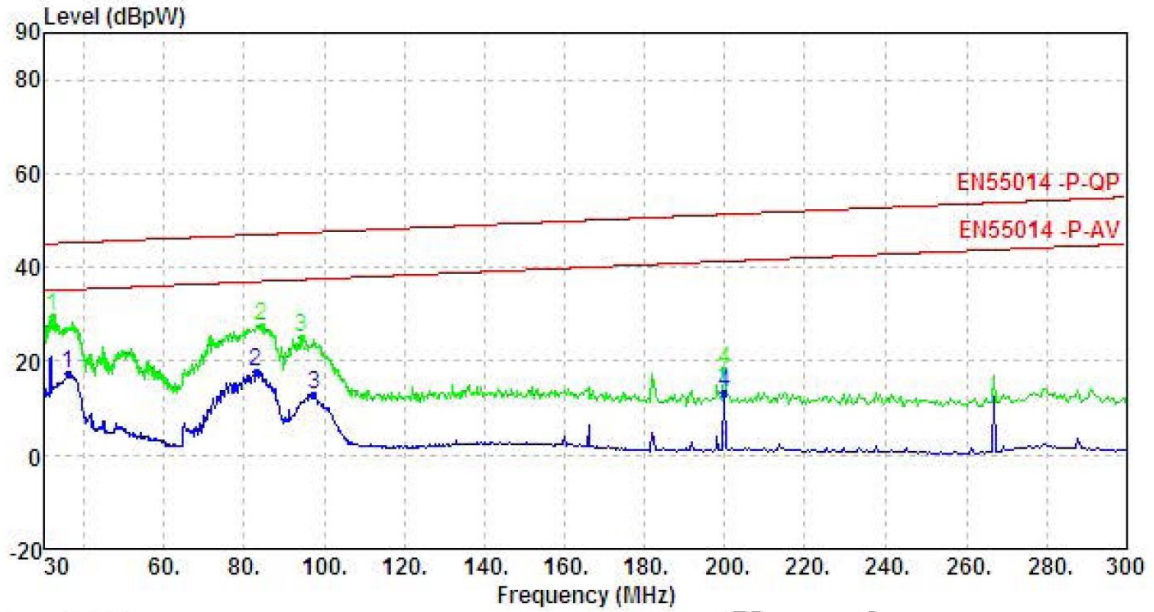

Condition:

: RBW:120.000KHz VBW:300.000KHz

Limit	Over			
Freq	Level	Line	Limit	Remark
MHz	dBpW	dBpW	dB	

1	M	36.07	17.14	35.24	-18.10	Average
2		83.01	17.65	36.97	-19.32	Average
3		97.53	12.83	37.51	-24.68	Average
4		200.04	13.33	41.31	-27.98	Average

Site : Shenzhen BST Technology Co., Ltd.

Condition:

: RBW:120.000KHz VBW:300.000KHz

Limit	Over			
Freq	Level	Line	Limit	Remark
MHz	dBpW	dBpW	dB	

1	M	32.29	29.54	45.10	-15.56	Peak
2		84.36	27.58	47.02	-19.44	Peak
3		94.43	25.16	47.40	-22.24	Peak
4		200.04	18.03	51.31	-33.28	Peak

5. HARMONIC CURRENT EMISSION TEST

5.1. Block Diagram of Test Setup

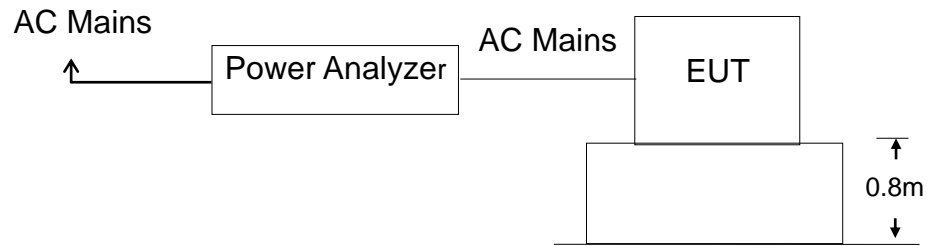

5.2. Test Standard

EN 61000-3-2

5.3. Operating Condition of EUT

- 5.1.1 Setup the EUT as shown in Section 5.1.
- 5.1.2 Turn on the power of all equipments.
- 5.1.3 Let the EUT work in test mode and test it.

5.4. Test Procedure

The power cord of the EUT is connected to the output of the test system. Turn on the power of the EUT and use the test system to test the harmonic current level.

5.5. Test Results

PASS

6. VOLTAGE FLUCTUATIONS & FLICKER TEST

6.1. Block Diagram of Test Setup

Same as Section 6.1.

6.2. Test Standard

EN 61000-3-3

6.3. Operating Condition of EUT

Same as Section 5.3.. The power cord of the EUT is connected to the output of the test system. Turn on the power of the EUT and use the test system to test the harmonic current level.

Flicker Test Limit

Test items	Limits
Pst	1.0
dc	3.3%
Tmax	4.0%
dt	Not exceed 3.3% for 500ms

6.4. Test Procedure

The power cord of the EUT is connected to the output of the test system. Turn on the power of the EUT and use the test system to test the harmonic current level.

6.5. Test Results

PASS

Please refer to the following page.

Flicker Test Data			
Temperature:	24.5 °C	Relative Humidity:	54%
Pressure:	1009hPa	Phase :	Vertical
Test Voltage:	AC 230V/50Hz	Test Mode:	ON

Voltage Fluctuation	Limit	Value
Relative Voltage Change Characteristic Tmax (dc>3%)	500 ms	0 ms
Maximum Relative Voltage Change dmax	4%	0.00
	6%	/
	7%	/
Relative Steady-state Voltage Change dc	3.3%	0.00

Flicker	Limit	Value
Short-term Flicker Indicator Pst	1.0	0.063
Long-term Flicker Indicator Plt	0.65	/

7. ELECTROSTATIC DISCHARGE IMMUNITY TEST

7.1. Block Diagram of Test Setup

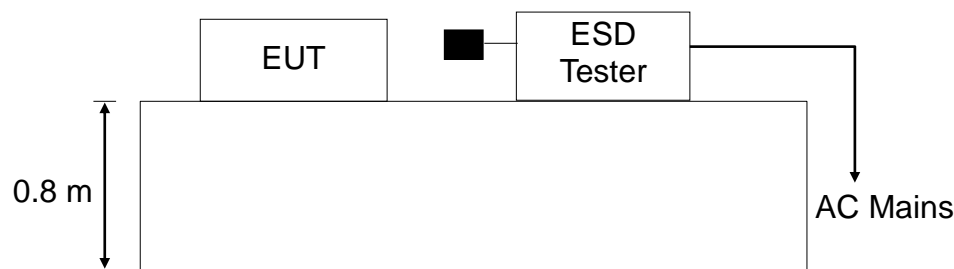

7.2. Test Standard

EN 55014-2, EN 61000-4-2

Severity Level: 3 / Air Discharge: ± 8 KV

Level: 2 / Contact Discharge: ± 4 KV

7.3. Severity Levels and Performance Criterion

7.3.1 Severity level

Level	Test Voltage Contact Discharge (KV)	Test Voltage Air Discharge (KV)
1.	± 2	± 2
2.	± 4	± 4
3.	± 6	± 8
4.	± 8	± 15
X	Special	Special

7.3.2 Performance criterion : B

- A.** The apparatus shall continue to operate as intended during the test. No degradation of performance or loss of function is allowed below a performance level (or permissible loss of performance) specified by the manufacturer, when the apparatus is used as i
- B.** The apparatus shall continue to operate as intended after the test. No degradation of performance or loss of function is allowed below a performance level (or permissible loss of performance) specified by the manufacturer, when the apparatus is used as intended. During the test, degradation of performance is allowed, however, no change of actual operating state or stored data is allowed. If the minimum performance level or the permissible performance loss is not specified by the manufacturer, then either of these may be derived from the product description and documentation, and from what the user may reasonably expect from the apparatus if used as intended.

- C.** Temporary loss of function is allowed, provided the function is self-recoverable or can be restored by the operation of the controls, or by any operation specified in the instructions for use.

7.4.EUT Configuration

The following equipments are installed on Electrostatic Discharge Immunity test to meet EN 55014-2, EN 61000-4-2, requirement and operating in a manner which tends to maximize its emission characteristics in a normal application. The configuration of EUT is the same as used in conducted emission test.

Please refer to Section 2.4.

7.5.Operating Condition of EUT

Same as conducted emission measurement, which is listed in Section 3.5 except the test setup replaced by Section 7.1.2.

7.6.Test Procedure

7.6.1 Air Discharge:

This test is done on a non-conductive surface. The round discharge tip of the discharge electrode shall be approached as fast as possible to touch the EUT. After each discharge, the discharge electrode shall be removed from the EUT. The generator is then re-triggered for a new single discharge and repeated 10 times for each pre-selected test point. This procedure shall be repeated until all the air discharge completed.

7.6.2 Contact Discharge:

All the procedure shall be same as Section 7.6.1. Except that the tip of the discharge electrode shall touch the EUT before the discharge switch is operated.

7.6.3 Indirect discharge for horizontal coupling plane

At least 10 single discharges (in the most sensitive polarity) shall be applied at the front edge of each HCP opposite the center point of each unit (if applicable) of the EUT and 0.1m from the front of the EUT. The long axis of the discharge electrode shall be in the plane of the HCP and perpendicular to its front edge during the discharge.

7.6.4 Indirect discharge for vertical coupling plane

At least 10 single discharges (in the most sensitive polarity) shall be applied to the center of one vertical edge of the coupling plane. The coupling plane, of dimensions 0.5m X 0.5m, is placed parallel to, and positioned at a distance of 0.1m from the EUT. Discharges shall be applied to the coupling plane, with this plane in sufficient different positions that the four faces of the EUT are complete illuminated.

7.7. Test Results

PASS

Please refer to the following page.

ESD Test Data				
Temperature:	24.5°C	Humidity:	53%	
Power Supply :	AC 230V/50Hz	Test Mode:	On	
Air Discharge: ± 8KV				
Contact Discharge: ± 4KV				
Test Points	Air Discharge	Contact Discharge	Performance Criterion	Result
Enclosure	±2,4,8KV	N/A	B	PASS
Slit	±2,4,8KV	N/A	B	PASS
Metal Part	N/A	±2,4 KV	B	PASS
VCP	N/A	±2,4 KV	B	PASS
HCP	N/A	±2,4 KV	B	PASS
Note: N/A				

8. RF FIELD STRENGTH SUSCEPTIBILITY TEST

8.1. Block Diagram of Test Setup

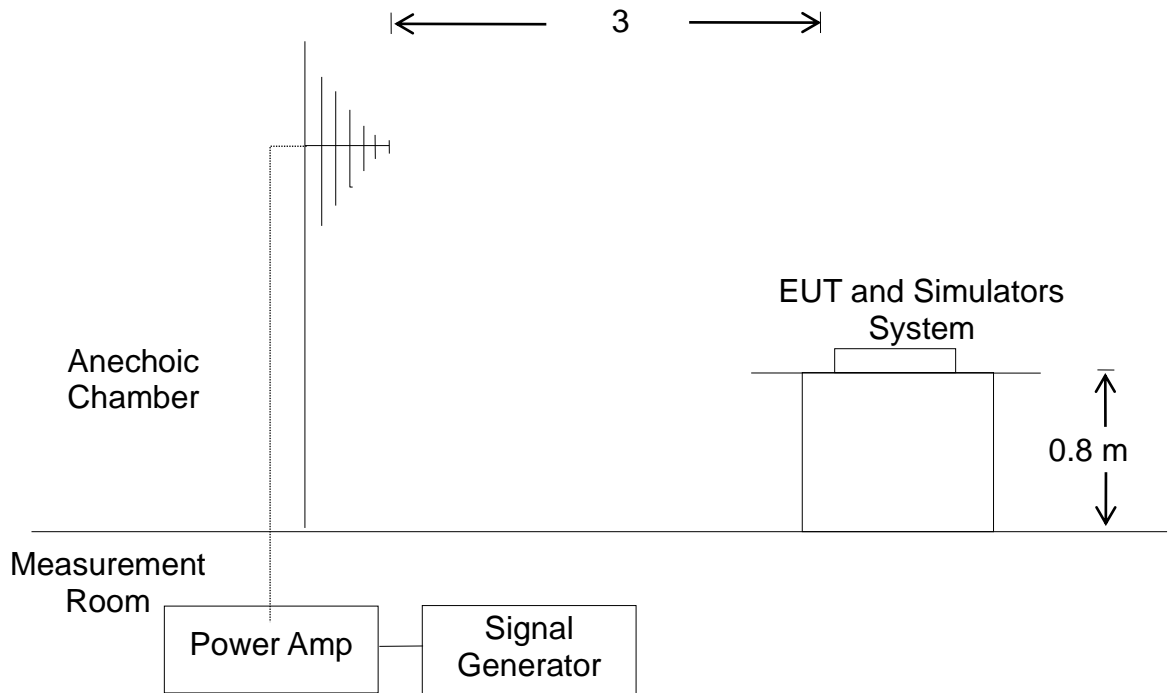

8.2. Test Standard

EN 55014-2, EN 61000-4-3

Severity Level 2, 3V / m

8.3. Severity Levels and Performance Criterion

8.3.1. Severity level

Level	Field Strength V/m
1.	1
2.	3
3.	10
X.	Special

8.3.2. Performance criterion: A

- A、 The apparatus shall continue to operate as intended during the test. No degradation of performance or loss of function is allowed below a performance level (or permissible loss of performance) specified by the manufacturer, when the apparatus is used as i

- B、 The apparatus shall continue to operate as intended after the test. No degradation of performance or loss of function is allowed below a performance level (or permissible loss of performance) specified by the manufacturer, when the apparatus is used as intended. During the test, degradation of performance is allowed, however, no change of actual operating state or stored data is allowed. If the minimum performance level or the permissible performance loss is not specified by the manufacturer, then either of these may be derived from the product description and documentation, and from what the user may reasonably expect from the apparatus if used as intended.
- C、 Temporary loss of function is allowed, provided the function is self-recoverable or can be restored by the operation of the controls, or by any operation specified in the instructions for use.

8.4.EUT Configuration on Test

The following equipments are installed on Electrical Fast Transient/Burst Immunity test to meet EN 55014-2, EN 61000-4-4:2012, requirement and operating in a manner which tends to maximize its emission characteristics in a normal application. The configuration of EUT is the same as used in conducted emission test.

Please refer to Section 3.4.

8.5.Operating Condition of EUT

Same as conducted emission measurement, which is listed in Section 2.5 except the test setup replaced by Section 8.1.

8.6.Test Procedure

The EUT and its simulators are placed on a turn table which is 0.8 meter above ground. EUT is set 3 meter away from the transmitting antenna which is mounted on an antenna tower. Both horizontal and vertical polarization of the antenna are set on test. Each of the four sides of EUT must be faced this transmitting antenna and measured individually.

All the scanning conditions are as follows :

Condition of Test	Remarks
1. Fielded Strength	3 V/m (Severity Level 2)
2. Radiated Signal	Modulated
3. Scanning Frequency	80 – 1000 MHz
4. Dwell time of radiated	0.0015 decade/s
5. Waiting Time	1 Sec.

8.7. Test Results

PASS

Please refer to the following page.

R/S Test Data			
Temperature : 25°C		Humidity : 53%	
Field Strength: 3 V/m		Criterion: A	
Power Supply: AC 230V/50Hz		Frequency Range: 80 MHz to 1000 MHz	
Modulation: <input checked="" type="checkbox"/> AM <input type="checkbox"/> Pulse <input type="checkbox"/> none 1 KHz 80%			
Test Mode : On			
		Frequency Range : 80-1000MHz	
Steps	1 %		
	Horizontal	Vertical	Result
Front	A	A	Pass
Right	A	A	Pass
Rear	A	A	Pass
Left	A	A	Pass
Note: N/A			

9. ELECTRICAL FAST TRANSIENT/BURST IMMUNITY TEST

9.1. Block Diagram of EUT Test Setup

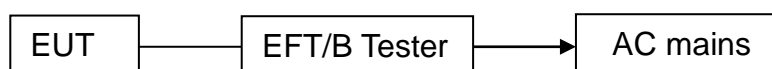

9.2. Test Standard

EN 55014-2, EN 61000-4-4

9.3. Severity Levels and Performance Criterion

Severity Level 2 at 1KV, Pulse Rise time & Duration: 5 nS / 50 nS

Severity Level:

Open Circuit Output Test Voltage $\pm 10\%$		
Level	On power ports	On I/O(Input/Output) Signal data and control ports
1.	0.5KV	0.25KV
2.	1KV	0.5KV
3.	2KV	1KV
4.	4KV	2KV
X.	Special	Special

Performance criterion: B

- A. The apparatus shall continue to operate as intended during the test. No degradation of performance or loss of function is allowed below a performance level (or permissible loss of performance) specified by the manufacturer, when the apparatus is used as i
- B. The apparatus shall continue to operate as intended after the test. No degradation of performance or loss of function is allowed below a performance level (or permissible loss of performance) specified by the manufacturer, when the apparatus is used as intended. During the test, degradation of performance is allowed, however, no change of actual operating state or stored data is allowed. If the minimum performance level or the permissible performance loss is not specified by the manufacturer, then either of these may be derived from the product description and documentation, and from what the user may reasonably expect from the apparatus if used as intended.
- C. Temporary loss of function is allowed, provided the function is self-recoverable or can be restored by the operation of the controls, or by any operation specified in the instructions for use.

9.4.EUT Configuration on Test

The following equipments are installed on Electrical Fast Transient/Burst Immunity test to meet EN 55014-2, EN 61000-4-4:2012, requirement and operating in a manner which tends to maximize its emission characteristics in a normal application. The configuration of EUT is the same as used in conducted emission test.

Please refer to Section 3.4.

9.5.Operating Condition of EUT

Same as conducted emission measurement, which is listed in Section 2.6 except the test setup replaced by Section 9.1.

9.6.Test Procedure

EUT shall be placed 0.8m high above the ground reference plane which is a min.1m*1m metallic sheet with 0.65mm minimum thickness. This reference ground plane shall project beyond the EUT by at least 0.1m on all sides and the minimum distance between EUT and all other conductive structure, except the ground plane beneath the EUT, shall be more than 0.5m

9.6.1. For input and output AC power ports:

The EUT is connected to the power mains by using a coupling device which couples the EFT interference signal to AC power lines. Both polarities of the test voltage should be applied during compliance test and the duration of the test is 2 minutes.

9.7. Test Results

PASS

Please refer to the following page.

EFT Test Data				
Temperature:	24.5°C		Humidity:	53%
Power Supply :	AC 230V/50Hz		Test Mode:	On
Coupling Line	Test Voltage		Performance Criterion	Result
	±0.5kV	±1kV		
L	±0.5kV	±1kV	B	PASS
N	±0.5kV	±1kV	B	PASS
L-N	±0.5kV	±1kV	B	PASS
PE	±0.5kV	±1kV	B	/
L-PE	±0.5kV	±1kV	B	/
N-PE	±0.5kV	±1kV	B	/
L-N-PE	±0.5kV	±1kV	B	/
DC Line	/	/		/
Note: N/A				

10. SURGE TEST

10.1. Block Diagram of EUT Test Setup

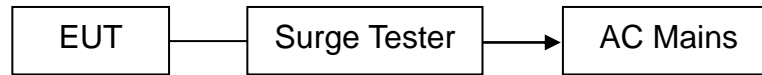

10.2. Test Standard

EN 55014-2, EN61000-4-5

10.3. Severity Levels and Performance Criterion

Severity Level: Line to Line, Level 2 at 1KV;

Severity Level: Line to Earth, Level 3 at 2KV.

Severity Level	Open-Circuit Test Voltage (KV)
1.	0.5
2.	1.0
3.	2.0
4.	4.0
X.	Special

Performance criterion: B

- A. The apparatus shall continue to operate as intended during the test. No degradation of performance or loss of function is allowed below a performance level (or permissible loss of performance) specified by the manufacturer, when the apparatus is used as i
- B. The apparatus shall continue to operate as intended after the test. No degradation of performance or loss of function is allowed below a performance level (or permissible loss of performance) specified by the manufacturer, when the apparatus is used as intended. During the test, degradation of performance is allowed, however, no change of actual operating state or stored data is allowed. If the minimum performance level or the permissible performance loss is not specified by the manufacturer, then either of these may be derived from the product description and documentation, and from what the user may reasonably expect from the apparatus if used as intended.
- C. Temporary loss of function is allowed, provided the function is self-recoverable or can be restored by the operation of the controls, or by any operation specified in the instructions for use.

10.4. EUT Configuration on Test

The following equipments are installed on Electrical Fast Transient/Burst Immunity test to meet EN 55014-2, EN61000-4-5:2014, requirement and operating in a manner which tends to maximize its emission characteristics in a normal application

The configuration of EUT is the same as used in conducted emission test. Please refer to Section 3.4.

10.5. Operating Condition of EUT

Same as conducted emission measurement, which is listed in Section 2.7 except the test setup replaced by Section 10.1.

10.6. Test Procedure

- 1) Set up the EUT and test generator as shown on section 10.1
- 2) For line to line coupling mode, provide a 1KV 1.2/50us voltage surge (at open-circuit condition) and 8/20us current surge to EUT selected points.
- 3) At least 5 positive and 5 negative (polarity) tests with a maximum 1/min repetition rate are conducted during test.
- 4) Different phase angles are done individually.
- 5) Repeat procedure 2) to 4) except the open-circuit test voltage change from 1KV to 2KV for line to earth coupling mode test.
- 6) Record the EUT operating situation during compliance test and decide the EUT immunity criterion for above each test.

10.7. Test Result

PASS

Please refer to the following page.

Surge Test Data						
Temperature:	24.5℃		Humidity:	53%		
Power Supply :	AC 230V/50Hz		Test Mode:	On		
Location	Polarity	Phase Angle	No of Pulse	Pulse Voltage (KV)	Performance Criterion	Result
L-N	+	90	5	1	B	Pass
	-	90	5	1		Pass
	+	270	5	1		Pass
	-	270	5	1		Pass
L-PE	+	90	5	2		/
	-	90	5	2		/
	+	270	5	2		/
	-	270	5	2		/
N-PE	+	90	5	2		/
	-	90	5	2		/
	+	270	5	2		/
	-	270	5	2		/

Note: N/A

11. INJECTED CURRENTS SUSCEPTIBILITY TEST

11.1. Block Diagram of EUT Test Setup

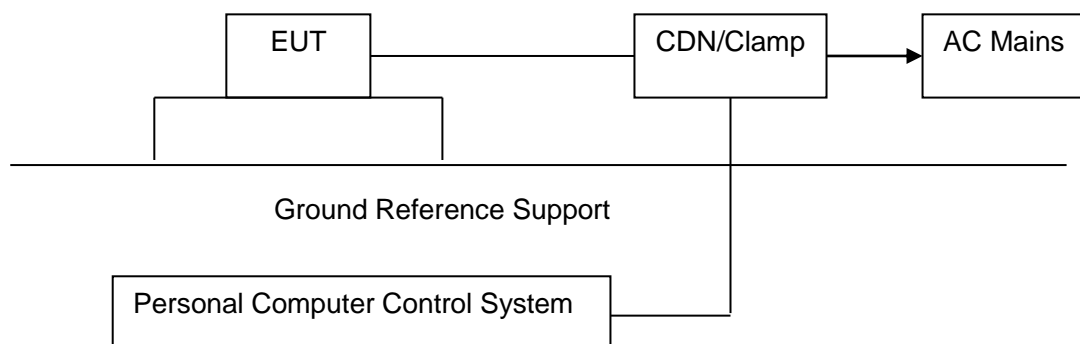

11.2. Test Standard

EN 55014-2, EN61000-4-6

11.3. Severity Levels and Performance Criterion

Severity Level 2: 3V(rms), 150KHz ~ 80MHz

Severity Level:

Level	Field Strength V
1.	1
2.	3
3.	10
X.	Special

Performance criterion: A

- A. The apparatus shall continue to operate as intended during the test. No degradation of performance or loss of function is allowed below a performance level (or permissible loss of performance) specified by the manufacturer, when the apparatus is used as i
- B. The apparatus shall continue to operate as intended after the test. No degradation of performance or loss of function is allowed below a performance level (or permissible loss of performance) specified by the manufacturer, when the apparatus is used as intended. During the test, degradation of performance is allowed, however, no change of actual operating state or stored data is allowed. If the minimum performance level or the permissible performance loss is not specified by the manufacturer, then either of these may be derived from the product description and documentation, and from what the user may reasonably expect from the apparatus if used as intended.

- C. Temporary loss of function is allowed, provided the function is self-recoverable or can be restored by the operation of the controls, or by any operation specified in the instructions for use.

11.4. EUT Configuration on Test

The configuration of EUT is the same as used in conducted emission test. Please refer to Section 2.8.

11.5. Operating Condition of EUT

Same as conducted emission test, which is listed in Section 2.8 except the test set up replaced as Section 11.1.

11.6. Test Procedure

- 1) Set up the EUT, CDN and test generator as shown on section 11.1
- 2) Let EUT work in test mode and measure.
- 3) The EUT and supporting equipments are placed on an insulating support 0.1m high above a ground reference plane. CDN (coupling and decoupling device) is placed on the ground plane at above 0.1-0.3m from EUT. Cables between CDN and EUT are as short as possible, and their height above the ground reference plane shall be between 30 and 50 mm (where possible).
- 4) The disturbance signal described below is injected to EUT through CDN.
- 5) The EUT operates within its operational mode(s) under intended climatic conditions after power on.
- 6) The frequency range is swept from 150KHz to 80MHz using 3V signal level, and with the disturbance signal 80% amplitude modulated with a 1KHz sine wave
- 7) The rate of sweep shall not exceed 1.5×10^{-3} decades/s. Where the frequency is swept incrementally, the step size shall not exceed 1% of the start and thereafter 1% of the preceding frequency value.
- 8) Recording the EUT operating situation during compliance test and decide the EUT immunity criterion for above each test.

11.7. Test Result

PASS

Please refer to the following page.

CS Test Data						
Temperature:		24.5°C		Humidity:		53%
Power Supply :		AC 230V/50Hz		Test Mode:		On
Frequency Range(MHz)	Injected Position	Strength	Modulation Signal	Freq. Step	Performance Criterion	Result
150KHz ~ 80MHz	AC Line	3V(rms), Unmodulated	AM 80%, 1kHz sine wave	1%	A	Pass
150KHz ~ 80MHz	DC Line	3V(rms), Unmodulated	AM 80%, 1kHz sine wave	1%	/	/
Note: N/A						

12. VOLTAGE DIPS AND INTERRUPTIONS TEST

12.1. Block Diagram of EUT Test Setup

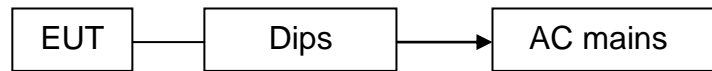

12.2. Test Standard

EN 55014-2, EN61000-4-11

12.3. Severity Levels and Performance Criterion

Severity Level:

Input and Output AC Power Ports.

- Voltage Dips.
- Voltage Interruptions.

Environmental Phenomena	Test Specification	Units	Performance Criterion
Voltage Dips	70	% Reduction period	C
	25		
Voltage Interruptions	40	% Reduction period	C
	10		
	0	% Reduction period	C
	0.5		

Performance criterion: B, C, C

- A. The apparatus shall continue to operate as intended during the test. No degradation of performance or loss of function is allowed below a performance level (or permissible loss of performance) specified by the manufacturer, when the apparatus is used as i
- B. The apparatus shall continue to operate as intended after the test. No degradation of performance or loss of function is allowed below a performance level (or permissible loss of performance) specified by the manufacturer, when the apparatus is used as intended. During the test, degradation of performance is allowed, however, no change of actual operating state or stored data is allowed. If the minimum performance level or the permissible performance loss is not specified by the manufacturer, then either of these may be derived from the product description and documentation, and from what the user may reasonably expect from the apparatus if used as intended.
- C. Temporary loss of function is allowed, provided the function is self-recoverable or can be restored by the operation of the controls, or by any operation specified in the instructions for use.

12.4. EUT Configuration on Test

The configuration of EUT is the same as used in conducted emission test. Please refer to Section 2.10.

12.5. Operating Condition of EUT

Same as conducted emission test, which is listed in Section 2.10 except the test set up replaced as Section 13.1.

12.6. Test Procedure

- 1) Set up the EUT and test generator as shown on section 13.1
- 2) The interruption is introduced at selected phase angles with specified duration. There is a 3mins minimum interval between each test event.
- 3) After each test a full functional check is performed before the next test.
- 4) Repeat procedures 2 & 3 for voltage dips, only the level and duration is changed.
- 5) Record any degradation of performance.

12.7. Test Result

PASS

Please refer to the following page.

DIPS Test Data			
Temperature:	24.5°C	Humidity:	53%
Power Supply :	AC 230V/50Hz	Test Mode:	On
Environmental Phenomena	Test Specification	Units	Performance Criterion
Voltage Dips	70	% Reduction period	C
	25		
	40 10	% Reduction period	C
Voltage Interruptions	0 0.5	% Reduction period	C

13. PHOTOS OF TEST SETUP



14. EUT PHOTOGRAPHS

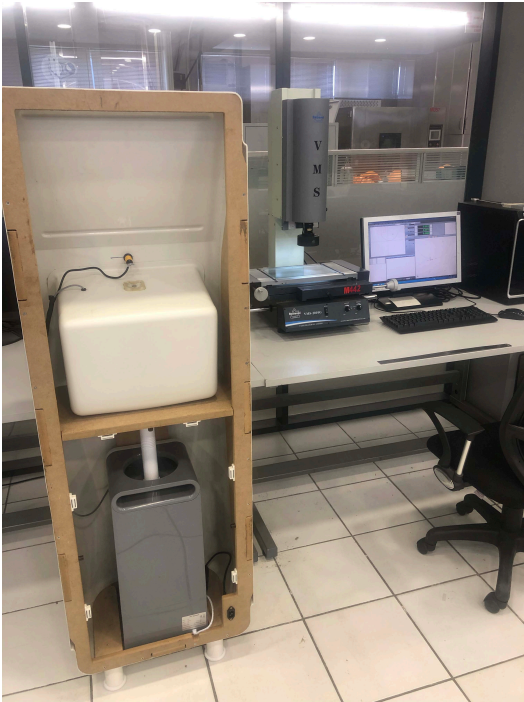



***** END OF REPORT *****